

4330 S. Johnson Rd. - Chanute, KS 66720
800-837-8578
info@popuphitch.com

Installation Instructions

Flip-Over Model 318 Dodge Ram & Mega Cab

Fits 2014 - 2016 (3/4 Ton only)
Long & Short Beds, 2WD & 4WD



www.popuphitch.com

FOR THE SAFEST INSTALLATION

11/15

WARNING Most pick up trucks have **FUEL LINES** and/or **BRAKE LINES** and/or **ELECTRICAL WIRING** positioned along the truck framersails where your under-bed hitch will install. **BEFORE INSTALLATION** identify and examine the location of fuel lines, brake lines and electrical wires. Be sure you will not damage fuel lines, brake lines or electrical wiring when positioning the hitch components, drilling holes or tightening fasteners. **Be Certain To Avoid Fuel Tanks When Drilling Holes.**

- Wear Safety Glasses, Gloves and Particle Mask for protection while installing a under-bed gooseneck hitch.
- ALWAYS correctly chock tires prior to raising truck with jacking device. For protection ALWAYS use jack stands when working under or around a truck which has been raised by a jacking device.
- Be certain the exhaust system is cool prior to installation to avoid possible burns from hot tail pipe and muffler.
- Torque ALL fasteners used in the under-bed gooseneck hitch installation as specified in these Installation Instructions.
- **READ ALL SAFETY AND WARNINGS ON THE LAST PAGE OF THE PROVIDED INSTRUCTIONS.**

INSTALLATION PROCEDURE

WARNING: Verify adequate trailer swing clearance between trailer nose and cab of truck, and trailer and rear of truck. READ spray in bed liner warning on last page.

- 1. Remove the spare tire (if needed).** To use the supplied hole location bracket simply insert it into center hole of the factory cross member from underneath truck. Then **use a marker or paint pen to mark the center hole**, use a center punch to **center the hole from underneath truck**. Then **drill a pilot hole** before using a **3 1/4"** hole saw to cut hole in bed of truck for ball socket to fit through. Smooth hole edges with file after sawing. Clean all saw tailings from the bed area before proceeding.
- 2.** Then slide the bolt blocks between the bed floor and the top of the factory cross member. Next use a screwdriver to line up the threads in the Bolt Block with the pre-drilled holes in the factory cross member.
- 3. In some cases** you may need to lower the exhaust by spraying soapy water on the rubber exhaust mount that is closest to the back of the truck and use a pry bar to slide the exhaust off of its mount.
- 4.** Insert the **1/2" spacer** between the bed floor and the factory cross member.
- 5.** Use a ratchet strap or cable through the ball socket to secure the hitch to a overhead lifting device or a sawhorse in the bed of the truck. Then raise the hitch up into the factory cross member location.
- 6.** To install the 5/8" flange bolts; start by installing the 4 outside bolts **finger tight to prevent the Bolt Blocks from turning**. Next install the 2 middle flange bolts and **torque all 6 fastners to torque specifications**. A small amount of Loc-Tite will help keep them secure.
- 7.** Next drill your 4 holes for the safety chain U-Bolts from underneath the truck. Be sure to keep your drill perpendicular with the cross member. Normally you use the outside set of holes furthest from the ball socket, but you want the safety chain u-bolts to land in the valley of the ribs in the bed floor.
- 8.** You can now let the tension off the ratchet strap and move your overhead lifting device/sawhorse out of the way.
- 9.** Install the 2 U-Bolts from the top of the bed. From under the bed place a spring and 1/2" nut on each U-bolt leg. **Tighten each nut until thread extends through the nut.**
- 10.** To Install the handle slide it through the **1" factory hole in the truck frame** behind the rear tire on the drivers side. Be careful not to damage the brake lines located on the back side of the frame.

INSTALLATION PROCEDURE- CONTINUED

11. Next attach the handle to the "Latch Arm" (see illustration below) using the supplied 5/16" X 5/8" clevis Pin and the 1-3/16" X 1/4" Cotter Hair Pin.
12. You can now re-attach the exhaust to its mount and put the spare tire back in place.
13. Keep the base of the Flip-Over ball lightly lubricated with **lithium grease**.
14. Please read the **SAFE TOWING INSTRUCTIONS** on the WARRANTY sheet. Fill out and return warranty card to us, or go online to www.popuphitch.com and fill out the online version.

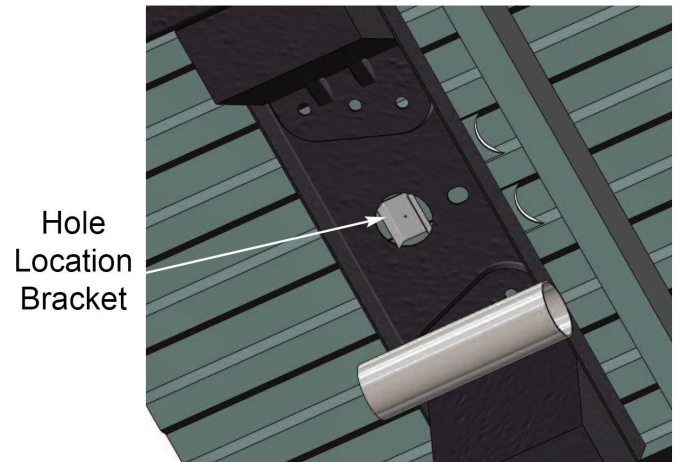
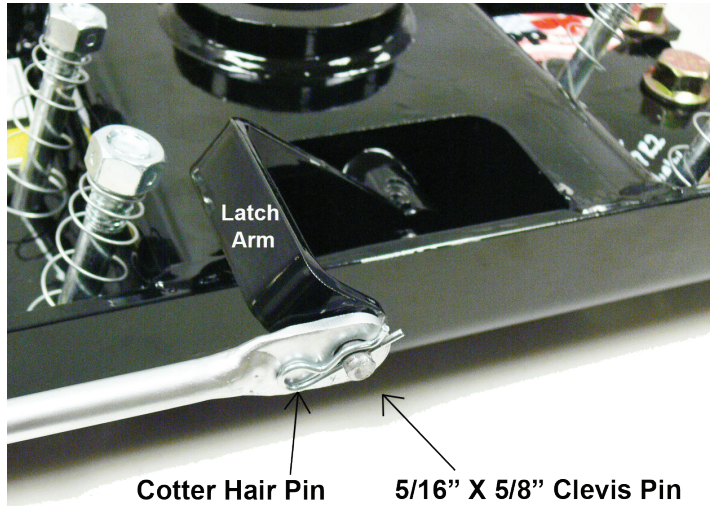

Torque Specifications:

5/8" Flange bolts - 112 ft. lbs.
Actuating rod set screw - 15 ft. lbs.

Hardware Provided

1- 1/2" Plastic Spacer
1- Pull Handle
1- 5/16" X 5/8" Clevis Pin
1- 1-3/16" X 1/4" Cotter Hair Pin
4- 5/8" X 1 1/2" Flange Bolt
2- U-Bolt Assembly
2- Bolt Blocks
1- Hole Location Bracket

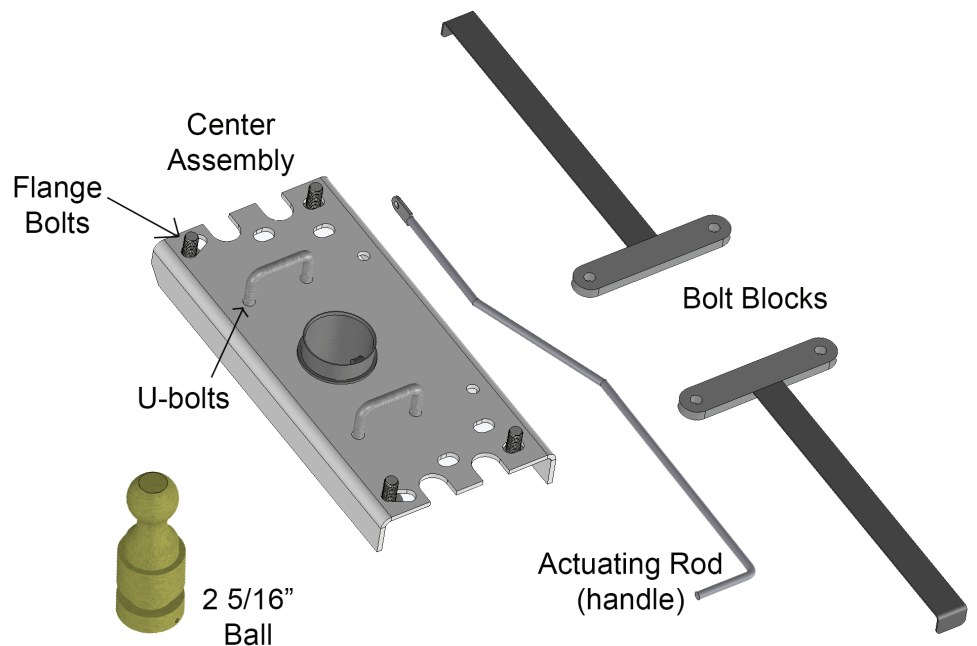

Please call or email with questions.
Call us at 800-837-8578 or
email us at info@popuphitch.com

Model Number 318
Gross Trailer Weight: 30M lbs.
Gross Trailer Tongue Weight: 7.5M lbs.

Flip-Over™



READ ALL SAFETY AND WARNINGS BEFORE STARTING THE INSTALL

WARNING AND SAFETY INFORMATION, READ ENTIRELY BEFORE INSTALLATION.

Read all installation and operating instructions along with all labels before using this product.

PopUp Towing's under-bed hitches are standard with a 2-5/16" ball. Make sure the coupler on the trailer is designed for 2-5/16" ball. Using a larger size coupler could cause loss of attachment and cause serious injury.

Do not modify this product in any manner. Doing so could alter the integrity and proper use of the product causing serious damage or injury.

Do not exceed tow or tongue rating of coupler, tow or tongue rating of the hitch, or tow or weight ratings of the truck or trailer. See vehicle and trailer manufacturer information for proper ratings. Exceeding these ratings may cause damage to truck and/or trailer, or possible bodily injury.

Adding components such as a PopUp Towing under-bed gooseneck hitch to the chassis of any vehicle can be hazardous. There is potential for unexpected combustion of fuel, electric shock, burns, shifting or falling of unstable vehicle, damage to vehicle, injury from tool usage and many other hazards. This installation must be completed by someone who is aware of the hazards involved.

Always be sure the ball is properly latched into place while in the up or down position. Before hauling heavy loads make sure that your hitch will clear the truck's differential before hauling a load.

Cab clearance can be an issue with short bed trucks and limits towing on certain trailers. Failure to insure that there is adequate clearance before towing, may result in property damage, or serious injury.

IMPORTANT: The hitch is designed to install only at the location described in the included instructions. Failure to place the ball hole precisely may result in property damage or difficulty during installation.

Failure to follow the bolt tightening sequence and torque settings listed above may result in the hitch being misaligned which could affect the performance of the hitch, or result in property or bodily damage.

PopUp Towing Products assumes no responsibility for injury to self, or damage that may occur during installation. As always its best to have this product installed by an experienced installer.

CAUTION: If your truck is equipped with a spray in bed liner that covers the rear lip of the truck bed, make sure and add the thickness of the bed liner to the hole location measurement before drilling the hole.