

Installation Instructions

Model 113

Chevy/GMC

Fits 1988-1998 1/2 Ton & 1988-2000

3/4 & 1 Ton Classic Body Style

Long Beds Only

Does Not Fit 1988-1991 Crew Cab



PopUp[®]
Towing Products
Mfg by Young's Products, LLC
4330 Johnson Rd.
Chanute, KS 66720
800-837-8578

MODEL 113 11-2010

FOR THE SAFEST INSTALLATION

WARNING Most pick up trucks have **FUEL LINES** and/or **BRAKE LINES** and/or **ELECTRICAL WIRING** positioned along the truck frame rails where your PopUp hitch will install. **BEFORE INSTALLATION** identify and examine the location of fuel lines, brake lines and electrical wires. Do not damage fuel lines, brake lines or electrical wiring when positioning PopUp hitch components, drilling holes or tightening fasteners. **Avoid Fuel Tanks When Drilling Holes.**

- Wear Safety Glasses, Gloves and a Particle Mask while installing a PopUp gooseneck hitch.
- ALWAYS correctly chock tires prior to raising truck with jacking device.
- ALWAYS use Jack Stands when working under or around a truck which has been raised by a jacking device.
- Allow the exhaust system to cool prior to installation to avoid possible burns from hot tail pipe and muffler.

INSTALLATION PROCEDURE

CAUTION: If larger after-market wheels and/or tires have been installed verify adequate Actuating Rod clearance.

CAUTION: Before mounting **SNOW CHAINS** verify adequate Actuating Rod clearance. Allow for suspension travel.

CAUTION: Verify adequate trailer swing clearance between trailer nose and cab or truck and trailer and rear of truck .

1. Mark and center punch a location **50-3/16"** from the rear lip of the truck bed centered between the wheel wells.

Center a 3" hole in this location using a 3" hole saw. Smooth the hole with a file and clean all saw tailings from the bed area before proceeding.

2. If using a vehicle hoist, raise the truck at this time. If using a jacking device Chock the front tires to prevent the truck from rolling. Jacking against the rear bumper or frame, lift the rear of the truck approximately 10". It is not necessary to lift the rear tires off the ground. Properly position jack stands under the rear frame of the truck to protect against jack failure.

3. Remove the entire exhaust heat shield or cut and remove the portion between the bed cross members where the hitch will install. Replace any screws used to secure any sections of heat shield not removed.

4. Identify the Front Cross Member, the longest of the two angles. With the plain side (2"leg) up and with the slotted side (2 1/2") facing the rear of the truck, slide the cross Member across the frame rails of the truck from the wheel well.. Position the Cross Member across the frame rails about 4" forward of the 3" hole.

5. Place the Rear Cross Member across the frame rails similiary, with the plain side (2" leg) up and with the slotted side facing forward. Position the Rear Cross Member about 4" behind the 3" hole.

6. With the hole for the pull rod facing the drivers side of the truck, raise the Ball Assembly into position between the Cross Members with the protruding tube fitting in the 3" hole. Place the Eye Bolt (provided) in the threaded hole in the top of the hitch ball and secure it to an overhead lifting device, or to a saw horse in the bed of the truck, and use cable or rope to hold the Ball Assembly firmly against the underside of the bed floor.

7. Use a muffler cutter or similar tool to grind both 1/4" bolts which extend through the frame rail on the driver side which hold the brake line brackets flush with the frame web.

8. Fasten the Center Assembly to the Front and Rear Cross Member using flat washers and 1 1/4" bolts. **Pull the slack out of the bolts but do not tighten at this time.** Square the assembled Cross Members and Center Assembly across the frame.

9. Fasten the Frame Plate tangs to the Crossmembers using 1 1/4" bolts with flat washers and lock nuts. **Pull the slack out of the bolts but do not tighten at this time.**

INSTALLATION PROCEDURE - CONTINUED

10. Fasten the Frame Plates to the frame by aligning two of the holes lower in the Frame Plate with existing holes in the truck frame.
Note: On some trucks factory holes may be missing and it may be necessary to drill 1/2" holes in the truck frame. Pass 1/2" x 1 1/4" bolts with flat washers from inside the frame and secure with 1/2" nuts. Do not fully tighten at this time.

11. Tighten the bolts in the following sequence. First tighten the bolts holding the Center Section to the Cross Bar and Angle. **Important:** Next, release the Center Section from the overhead lifting device. Check to ascertain that the cross angle and bar are resting securely on the frame. Next tighten the Frame Plates to the frame, then Cross Members to the Frame Plates, Follow the torque guidelines listed below.

12. Drill four 1/2" holes for the Safety Chain anchors through the pairs of holes closest to the ball in web of channel from under the truck bed. Place a U-bolt in each pair of holes from the top side of the bed. From under the bed place a spring and 1/2" lock nut on each U-bolt leg. Tighten each nut until thread extends through the nut.

13. In the driver side wheel well, mark a location 4" forward of the Actuating Rod and mark a location 4" rearward of the Actuating Rod on the 3/4" lip where the fender liner and truck bed floor are joined. Use a sawsall to remove the lip. (Or use a muffler cutter or tin snips and make a vertical cut at each marked location 3/4" deep. Fold the lip section between the two cuts inward and upward to a position level with the bottom of the bed floor. Use vise-grips and/or a prying bar levered against the top of the Frame Plate).

14. Pass the Actuating Rod through the slotted hole between the Frame Plate extensions and into the hole in the slide. Align the Actuating Rod and secure using the 1/4" bolt. Seat the bolt in the hole in the rod, and tighten to 7 foot pounds. Ascertain that the rod is free in the frameplate and doesn't drag.

15. Be certain all hitch fasteners are torqued as specified in these installation instructions.

IMPORTANT!

The final step is to raise the ball and check the position of the slide from under the truck.

When the ball is fully raised, the Roll Pin Stop should be against the ball tube. This allows the Detent Ball to lock the slide in place and positions the ball over the flat surface at top of the slide.

In this position it is impossible for the ball to retract without manually pushing in the handle.

Read the **SAFE TOWING INSTRUCTIONS** on the **PopUp Warranty** sheet.

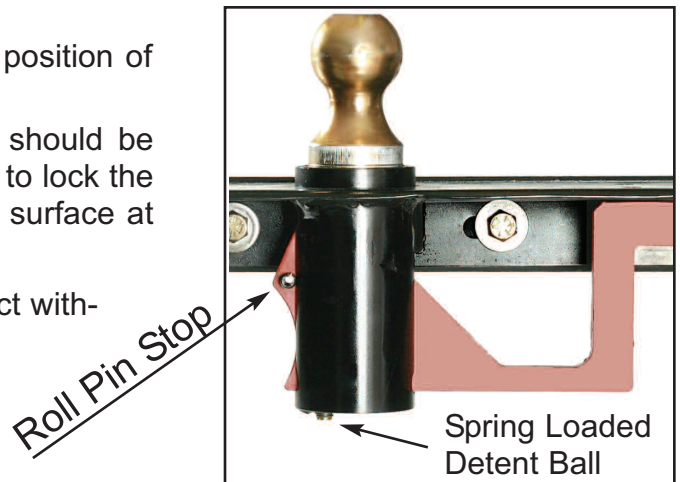

HARDWARE PROVIDED

- 16 - 1/2" X 1-1/4" Grd. 8 Bolts
- 20 - 1/2" Lock Nuts
- 20 - 1/2" Flat Washers
- 2 - U-Bolts
- 4 - 9/16" X 3" Springs
- 1 Plastic Cap
- 1 - 3/8" eye bolt



PopUp²
www.popuphitch.com

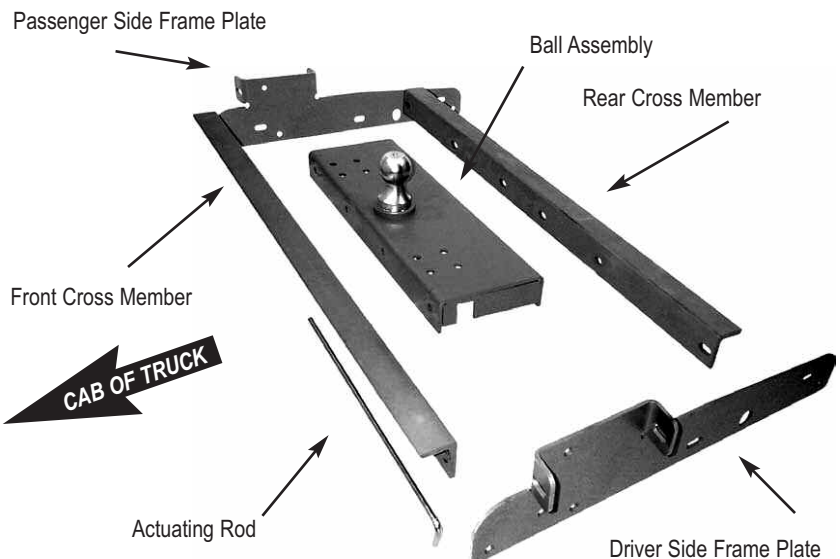

Model Number 113
Gross Trailer Weight: 30M lbs.
Gross Trailer Tongue Weight: 7.5M lbs.

IMPORTANT!

Before installing the actuating rod place the indicator / lock collar on the rod toward the bend for the handle.

As a last step firmly pull the handle to raise the ball, verify that the Roll Pin Stop is against the ball tube. Then slide the indicator / lock collar against the outside of the frame plate and secure it in this position using a 1/8" allen wrench.

With the indicator / lock collar in place raise the actuator rod slightly and push in to lower the ball. To raise the ball raise the handle and pull the actuator rod out till the indicator / lock collar clears the frame plate. This gives a positive indication that the ball is fully raised and is ready for towing.

Pop^{up}[®] Towing Products
Mfg by Young's Products, LLC

Indicator /
Lock Collar



Roll Pin
Stop

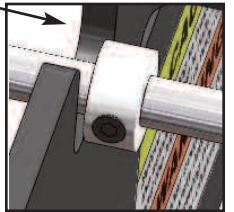

Frame
Plate