

Flip-Over™

PopUp Industries, Inc.
4330 Johnson Rd., Chanute, KS 66720
877-339-5704
www.popuphitch.com info@popuphitch.com

Installation Instructions

Model 218 Chevrolet / GMC

1999-2008:
1500, 1500HD
2500, 2500HD, 3500



Model 218 3/07

FOR THE SAFEST INSTALLATION

WARNING Most pick up trucks have **FUEL LINES** and/or **BRAKE LINES** and/or **ELECTRICAL WIRING** positioned along the truck frame rails where your Flip-Overhitch will install. **BEFORE INSTALLATION** identify and examine the location of fuel lines, brake lines and electrical wires. Be sure you will not damage fuel lines, brake lines or electrical wiring when positioning the hitch components, drilling holes or tightening fasteners. **Be Certain To Avoid Fuel Tanks When Drilling Holes.**

- Wear Safety Glasses, Gloves and Particle Mask for protection while installing a Flip-Over gooseneck hitch.
- ALWAYS correctly chock tires prior to raising truck with jacking device. For protection in case of jacking device failure ALWAYS use Jack Stands when working under or around a truck which has been raised by a jacking device.
- Be certain the exhaust system is cool prior to installation to avoid possible burns from hot tail pipe and muffler.
- Torque ALL fasteners used in the Flip-Over gooseneck hitch installation as specified in these Installation Instructions.

INSTALLATION PROCEDURE

WARNING: Verify adequate trailer swing clearance between trailer nose and cab of truck, and trailer and rear of truck.

1. Mark and center punch a location from the rear lip of the truck bed (tailgate end) centered between the wheel wells for the **specific truck** the hitch is being installed in, as stated below:

Short Bed Trucks 46-3/8"

Long Bed Trucks 51-5/8"

Center a hole in this location using a 3-1/2" hole saw. Smooth the hole with a file and clean all saw tailings from the bed area before proceeding.

2. Remove the spare tire. If using a vehicle hoist, raise the truck at this time. If using a jacking device Chock the front tires to prevent the truck from rolling. Jacking against the rear bumper or frame, lift the rear of the truck approximately 10". It is not necessary to lift the rear tires off the ground. Properly position jack stands under the rear frame of the truck to protect against jack failure.

3. Remove the entire exhaust heat shield or cut and remove the portion between the bed cross members where the hitch will install. Replace any screws used to secure any sections of heat shield not removed. Also, on 2500HD and 3500 trucks cut 1" off of the top of the rearward 4" of the metal shield that protects the fuel tank. This will provide clearance for the Center Assembly (3).

4. Identify the Rear Cross Member 1" X 2" bar (1). Pass it through the driver side wheel well across the top of the frame rails with the bar oriented with the **threaded holes nearest the bottom side**. Center the Cross Member across the frame rails 3" behind the 3-1/2" hole.

5. To install the Front Cross Member it is necessary to cut a notch in the lip above the frame where the inner fender and bed floor join. Cut and remove a notch as shown in the illustration 4" ahead of the truck bed sill cross member ahead of the axle where the hitch will install. Pass the Front Cross Member (2) over the frame through the notch and position across the frame rails with the plain side up and with the hole side facing the rear of the truck. Center the Cross Member across the frame rails and 6" ahead of the 3-1/2" hole.

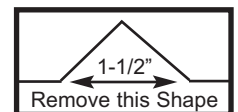

6. Raise the Center Assembly (3) into position under the truck bed with the protruding tube passing into the 3-1/2" hole. Use an overhead lifting device, or a saw horse in the bed of the truck, and cable or rope to hold the Center Assembly firmly against the underside of the bed floor.

INSTALLATION PROCEDURE - CONTINUED

7. Fasten the Center Assembly to the Rear Cross Member using washers, 1/2" X 1-1/2" bolts and 1/2" nuts. Slide the Front Cross Member rearward and fasten it to the Center Assembly with 1/2" X 1-1/2" bolts and 1/2" nuts. Tighten the fittings in the Front Cross Member. Leave the fittings in the Rear Cross Member very loose at this time. Square the assembled Cross Members and Center Assembly across the frame.

8. Identify the driver side (4, with labels) and passenger side Frame Plates. Fasten the frame plates to the cross bar and angle with 1 1/2" x 1/1" bolts. Tighten Rear Cross Member only.

9. Fasten the Frame Plates to the frame by passing a 3/4" bolt with a flat washer through the slotted hole from inside the frame and securing using a flat washer and nut. Drill 1/2" holes in the truck frame through the 1/2" hole located in the Frame Plates between the extensions. Use the upper hole for 1500, 1500HD and 2500 Light Duty trucks. Use the lower hole for 2500HD and 3500 trucks. CAUTION: Avoid fuel tank, brake lines and/or wiring. Pass 1/2" X 1-1/2" bolts from inside the frame and secure with 1/2" nuts. Do not fully tighten at this time.

10. **Torque 1/2" fasteners to 65 foot pounds** in the following sequence: First the Cross Members to Center Assembly, then the Cross Members to the Frame Plates, and last the Frame Plates to the truck frame. **Torque 3/4" fasteners to 70 foot pounds.**

11. From the driver side, pass the Actuating Rod (6) through the 1/2" hole (NOT the slotted hole) between the Frame Plate extensions and into the linkage coupler. Align the Actuating Rod so the set screw seats in the hole provided in the rod, and tighten to 15 foot pounds. Be certain the Actuating Rod rotates freely and be certain it moves in and out freely.

12. Drill four 1/2" holes for the Safety Chain Brackets from under the truck bed. Drill through the two pairs of holes in the Center Assembly that are **nearest to the hitch ball**. Place a U-bolt in each pair of holes from the top side of the bed. From under the bed place a spring and 1/2" nut on each U-bolt leg. Tighten each nut until thread extends through the nut.

13. Retract the Retaining Pin by rotating the Actuating Rod 90 degrees counter clockwise. Place the Flip-Over ball in the Socket. Rotate the Actuating Rod 90 degrees clockwise to engage the Retaining Pin.

14. Keep the base of the Flip-Over ball lightly lubricated with lithium grease.

15. Please read the **SAFE TOWING INSTRUCTIONS** on the Flip-Over WARRANTY sheet.

HARDWARE PROVIDED

- 16 - 1/2" X 1-1/2" Grd. 8 Bolts
- 10 - 1/2" Lock Nuts
- 12 - 1/2" Flat Washers
- 2 - 3/4" X 2" Grd. 5 Bolts
- 2 - 3/4" Nuts
- 4 - 3/4" Flat Washers
- 2 - U-Bolts w/springs and nuts

Flip-Over™

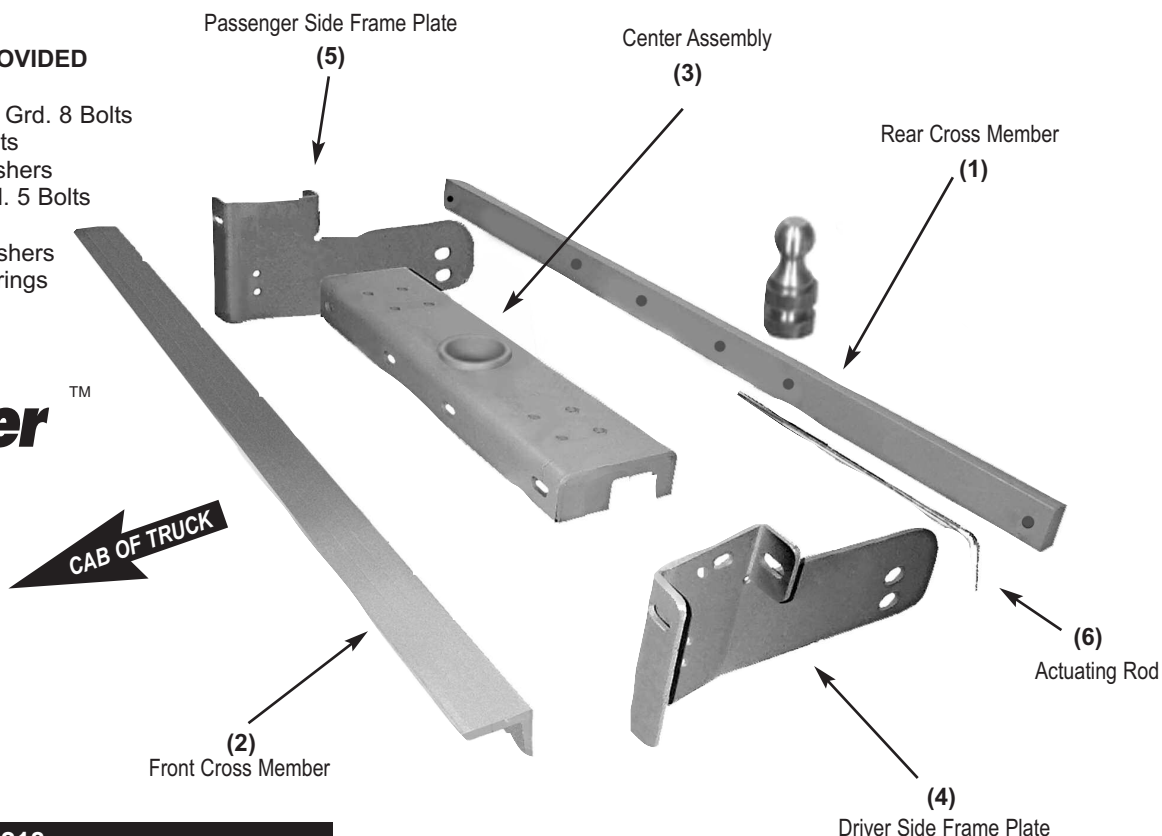

Model Number 218
Gross Trailer Weight: 30M lbs.
Gross Trailer Tongue Weight: 7.5M lbs.

Patent Pending